

ZASUWA NOŻOWA DWUKIERUNKOWA Z TRZPIENIEM WZNOŚCĄCYM DN50-DN600 PN10

BI-DIRECTIONAL RISING STEM KNIFE GATE VALVE DN50-DN600 PN10

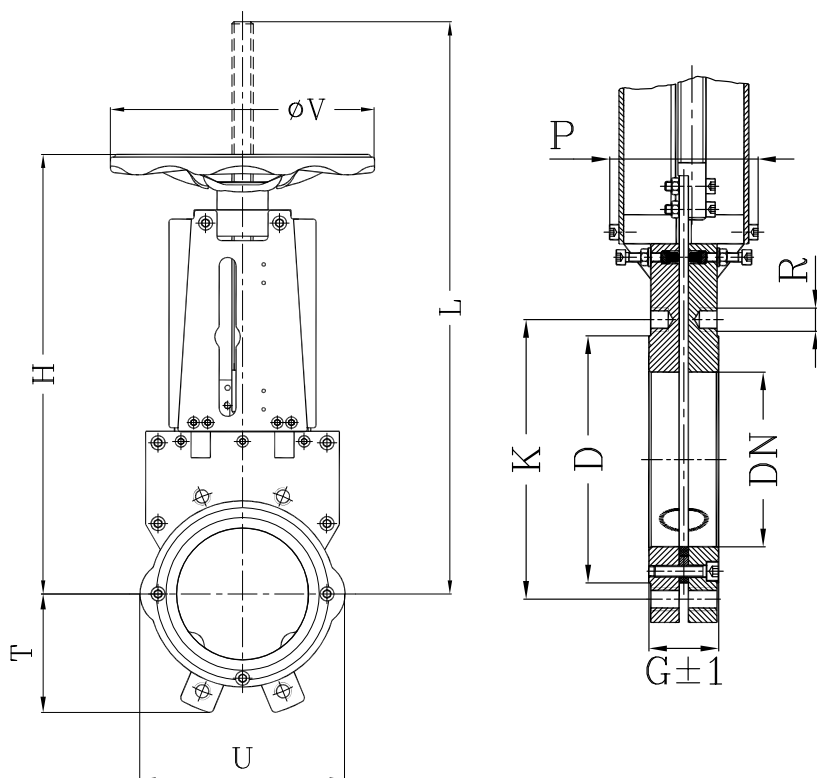

WYKONANIE WG. NROMY DESIGN STANDARD	EN 1171
DŁUGOŚĆ ZABUDOWY FACE TO FACE	DIN 558-1 Seria 20
KOŁNIERZE FLANGES	EN 1092-2
TESTOWANIE WG. NORMY TESTS	EN 12266
TEMPERATURA ROBOCZA WORKING TEMPERATURE	EPDM ≤ 120°C

CIŚNIENIE ROBOCZE/WORKING PRESSURE

DN50-DN150 10 Bar	DN200-DN350 8 Bar	DN300-DN350 6 Bar
DN400-DN450 5 Bar	DN500-DN600 4 Bar	Testowanie: 1,5x ciśnienie robocze

DN	G±1	H	K	D	R	L	ØV	T	U	P	Kg
50	43	267	125	100	M16	335	175	65	130	-	9
65	46	293	145	120	M16	376	175	72	144	-	10
80	46	334	160	135	M16	419	225	97	152	110	13
100	52	371	180	158	M16	476	225	108	165	110	15
125	56	411	210	188	M16	541	225	122	195	112	17
150	56	500	240	212	M20	651	300	135	233	118	26
200	60	602	295	268	M20	803	300	170	276	122	37
250	68	703	350	320	M20	954	300	202	328	124	60
300	78	835	400	370	M20	1137	400	233	377	138	72
350	78	921	460	430	M20	1273	400	257	438	148	130
400	90	1031	515	482	M24	1433	400	290	486	152	150
450	90	1161	565	532	M24	1604	500	313	560	190	220
500	95	1271	620	585	M24	1779	500	320	635	195	240
600	105	1458	725	685	M27	2066	500	412	731	195	325

Nr N°	NAZWA CZĘŚCI PART NAME	MATERIAŁ MATERIAL
1	KÓŁKO HANDWHEEL	Stal ST37 pokryta Epoksydem Epoxy coated ST37 steel
2	ŁOŻYSKO BUSHING	Stal ST52 pokryta Epoksydem Epoxy coated ST52 steel
3	WSPORNIK SUPPORT	Stal ST52 pokryta Epoksydem Epoxy coated ST52 steel
4	TRZPIEŃ STEM	Stal nierdzewna AISI616 AISI316 Stainless steel
5	ŚRUBY I NAKRETKI BOLT AND NUTS	Stal A4 A4 Steel
6	GÓRNA USZCZELAKA TOP SEALING	Guma EPDM EPDM rubber
7	KORPUS BODY	Żeliwo szare GJL250 CastI ron GJL250
8	NÓŻ KNIFE	Stal nierdzewna AISI616 AISI316 Stainless steel
9	USZCZELKA SEALING	Guma EPDM EPDM rubber

Wszystkie powierzchnie z żeliwa pokryte są proszkiem epoksydowym 3M metodą fluidyzacyjną. Minimalna grubość pokrycia 250µm.
 All surfaces made of Ductile Iron are coated with FBE resin powder 3M. Minimum thickness of 250 µm.

ZASUWA NOŻOWA DWUKIERUNKOWA Z TRZPIENIEM NIEWZNOŚZĄCYM DN50-DN600 PN10

BI-DIRECTIONAL NON-RISING STEM KNIFE GATE VALVE DN50-DN600 PN10

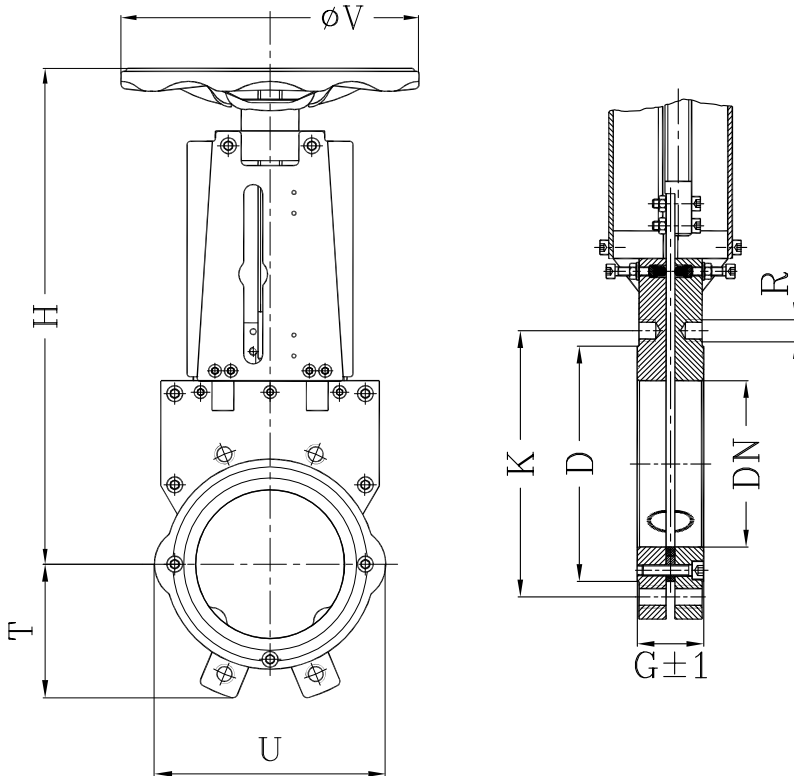

DN	G±1	H	K	D	R	ØV	T	U	Kg
50	43	267	125	100	M16	175	65	130	9
65	46	293	145	120	M16	175	72	144	10
80	46	334	160	135	M16	225	97	152	13
100	52	371	180	158	M16	225	108	165	15
125	56	411	210	188	M16	225	122	195	17
150	56	500	240	212	M20	300	135	233	26
200	60	602	295	268	M20	300	170	276	37
250	68	703	350	320	M20	300	202	328	60
300	78	835	400	370	M20	400	233	377	72
350	78	921	460	430	M20	400	257	438	130
400	90	1031	515	482	M24	400	290	486	150
450	90	1161	565	532	M24	500	313	560	220
500	95	1271	620	585	M24	500	320	635	240
600	105	1458	725	685	M27	500	412	731	325

WYKONANIE WG. NROMY DESIGN STANDARD	EN 1171
DŁUGOŚĆ ZABUDOWY FACE TO FACE	DIN 558-1 Seria 20
KOŁNIERZE FLANGES	EN 1092-2
TESTOWANIE WG. NORMY TESTS	EN 12266
TEMPERATURA ROBOCZA WORKING TEMPERATURE	EPDM≤120°C

CIŚNIENIE ROBOCZE/WORKING PRESSURE

DN50-DN150 10 Bar	DN200-DN350 8 Bar	DN300-DN350 6 Bar
DN400-DN450 5 Bar	DN500-DN600 4 Bar	Testowanie: 1,5x ciśnienie robocze

Nr N°	NAZWA CZĘŚCI PART NAME	MATERIAŁ MATERIAL
1	KÓŁKO HANDWHEEL	Stal ST37 pokryta Epoksydem Epoxy coated ST37 steel
2	ŁOŻYSKO BUSHING	Stal ST52 pokryta Epoksydem Epoxy coated ST52 steel
3	WSPORNIK SUPPORT	Stal ST52 pokryta Epoksydem Epoxy coated ST52 steel
4	TRZPIEŃ STEM	Stal nierdzewna AISI616 AISI316 Stainless steel
5	ŚRUBY I NAKRETKI BOLT AND NUTS	Stal A4 A4 Steel
6	GÓRNA USZCZELAKA TOP SEALING	Guma EPDM EPDM rubber
7	KORPUS BODY	Żeliwo sferoidalne GJS500-7 Ductile Iron GJS500-7 EN1563
8	NÓŻ KNIFE	Stal nierdzewna AISI616 AISI316 Stainless steel
9	USZCZELKA SEALING	Guma EPDM EPDM rubber

Wszystkie powierzchnie z żeliwa pokryte są proszkiem epoksydowym 3M metodą fluidyzacyjną. Minimalna grubość pokrycia 250µm.
All surfaces made of Ductile Iron are coated with FBE resin powder 3M. Minimum thickness of 250 µm.